



Making An Uchiwa Fan (3 Variations)

Grade Level: Adaptable for 4th - 7th Grade

Art Content Standard: Historical , Cultural and Social Context: Benchmark B
Creative Expression: Benchmark A, B, C, E

Vocabulary/ Concepts: Japanese culture
Fan symbolism
History of fans
Uchiwa
Hiogi
Komori ogi
Ogi-e

Materials: 9 thin Popsicle sticks per student
6 fat Popsicle students per student
Fan pattern (plain and/or floral, both included)
Fan direction sheet (included)
Markers
Fine tip permanent marker
Pencils
Colored Pencils
Crayons
Watercolors
Wallpaper sheets
Stiff paper
Stapler
Ruler
Glue
Masking tape
Scissors
Scraps of yarn, ribbon, cord, tassels, etc.
Japanese art books or pictures for examples of fans

Procedure: 1. Discuss Japanese culture and the history of fans.
2. Follow directions on included Fan Direction Sheet

Enrichment Activities: Students could create one of the other types of Japanese fans.
1. Hiogi - crescent folding
2. Ogi-e - fan painting
3. Komori ogi - paper fan

Lesson prepared by: Judy Zimmerman
Sandy Valley Elementary



Variation 1 – Haiku and the Making of an Uchiwa Fan

Grade Level: 4th Grade

Additional Content Standard: English Language Arts Grade Four: Indicator 5

Additional Vocabulary/ Concepts: Haiku being inspired by nature

Procedure: 1. Discuss Japanese culture and the history of fans.
2. Show examples from Internet and/or books provided.
3. Explain Haiku poetry and share some examples.
4. Lead students through an imagery experience such as:
Close your eyes and imagine yourself at a body of water. Is the water calm? Rough? What color is the water? (Etc.)
Open your eyes and describe your scene on paper.
5. Use scene to write Haiku.
6. Discuss the Uchiwa fan and the steps to make one. (Use included direction sheet for steps.)
7. Students will follow steps to create their fan.
8. Students will include their Haiku as part of the fan's design.
9. Outline the Haiku in fine tip marker.

Assessment: Students will create a decorated Uchiwa fan with a nature inspired Haiku. A rubric could be created to give formal assessment.

Variation prepared by: Shelley Speranzini
Sacred Heart of Mary

Variation 2 – Creating an Uchiwa Fan

Grade Level: 5th and 6th Grade

- Procedure:**
1. Discuss history of fans.
 2. Put vocabulary (types of fans) on the board.
 3. Discuss and show Japanese art styles, including designs inspired by nature. (Use Internet and books from library.)
 4. Pass out 2 types of Popsicle sticks, glue, rulers and fan pattern.
 5. Students choose a piece of stiff paper for the back of their fan.
 6. Pass out pattern. Students need to trace and cut out fan. (They may decorate later if they choose.)
 7. Together, using the included direction sheet, put fan ribs together as a class and let dry.
 8. Allow students to choose the type of paper and materials to decorate the top part of their fan.
 9. Glue top part of their fan to the ribs. Decorate with remaining ribbon or yarn.

Assessment: Students will be able to discuss why fans were made and the symbolism behind them. Students will show their knowledge of Japanese design by using nature inspired designs on their fans.

Variation prepared by: Vonda White
Sacred Heart of Mary

Variation 3 – Japanese Fans

Grade Level: 7th Grade

Additional Materials: Various books with history of fans
White and colored computer paper
Giant post-it note paper
Transparencies of fans

- Procedure:** *Day 1*
1. Discuss general history of fans throughout various civilizations.
 2. Group children in groups of two or three per group.
 3. Use Internet and books for students to research more history of fans and to research symbolism of fans.
 4. Students are to take notes as they research.

Day 2

1. Pass out large Post-it notes and markers (one per group).
2. Allow 10 to 15 minutes for groups to collaborate and write findings onto large Post-it note paper.
3. Groups share findings.
4. Teacher will discuss types of Japanese fans using pre-made transparencies.

Day 3

1. Review fan styles and show samples of Hiogi and Uchiwa fan.
2. Demonstrate how to make Hiogi fan -- Pass out stiff paper or wallpaper 8 ½ by 11.
3. Fold paper horizontally ½ inch in accordion style.
4. Staple end of fan ½ – 1 inch from the bottom.
5. Tie tassel around handle of fan.
6. Demonstrate how to make Uchiwa fan-- Pass out 9 Popsicle sticks, 6 large Popsicle sticks, 1 plain fan pattern and 1 floral pattern per child.
7. Cut out both patterns.
8. Trace around fan front on stiff paper and cut out the shape, this will be the back of the fan to decorate.
9. Glue 2 Popsicle sticks together 1 inch overlap, the two sticks the two sticks together should become 8 inches long, this is one rib of the fan.
10. Continue following included direction sheet.

Assessment: Students will be able to write two paragraphs about the history and symbolism of fans. Students will discuss and analyze individual fans.

Lesson prepared by: Rosemary Laughlin
Sacred Heart of Mary School

Floral Fan Pattern

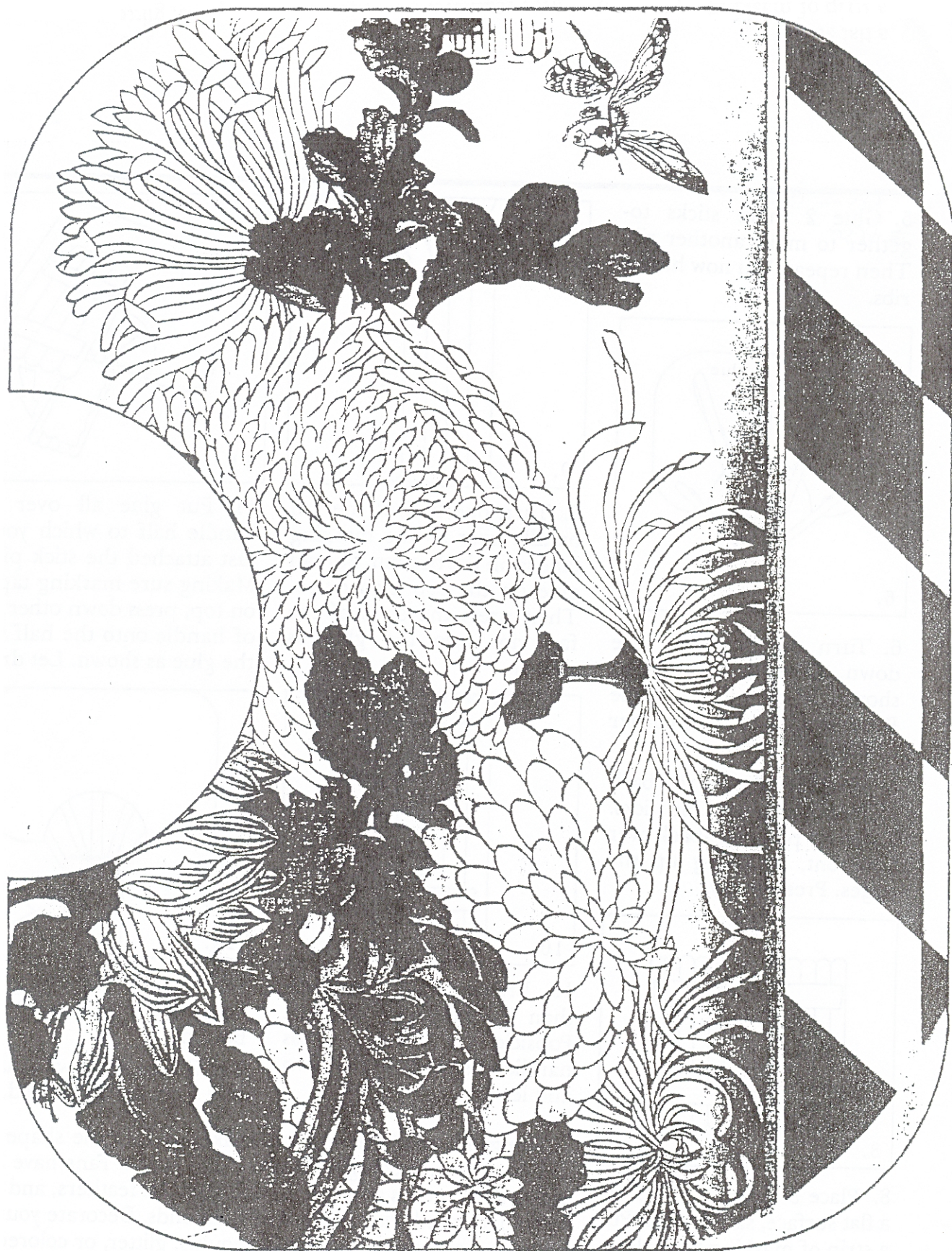

Plain Fan Pattern

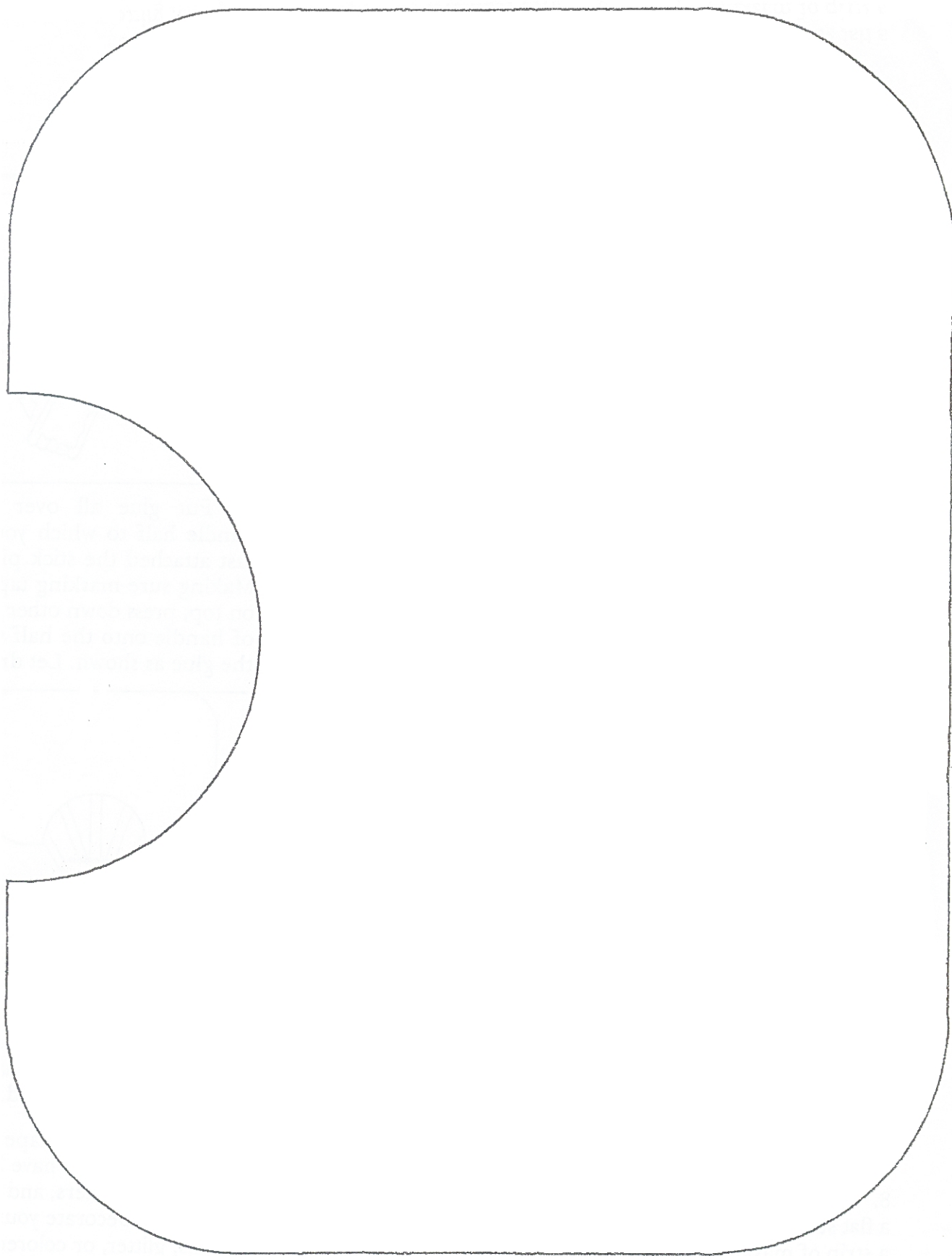

Fan Direction Sheet

1. Cut our fan-front along outline.

2. Trace around fan-front on paper and cut out shape. This will be the back of the fan, for you to decorate.

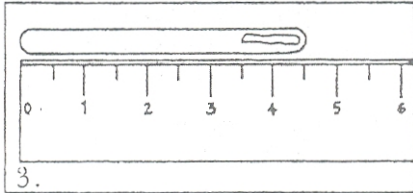

3. Lay a small Popsicle stick next to the ruler so that one end lines up with zero. Put about an inch of glue on the other end of the stick as shown.

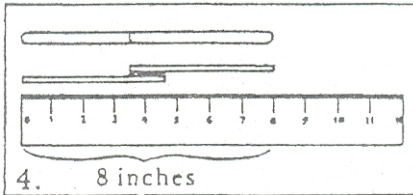

4. Place a second small stick over the first so the 2 sticks together become 8 inches long. Press the sticks together. This is one "rib" for the fan.

5. Glue 2 more sticks together to make another rib & repeat. You now have 3 ribs.

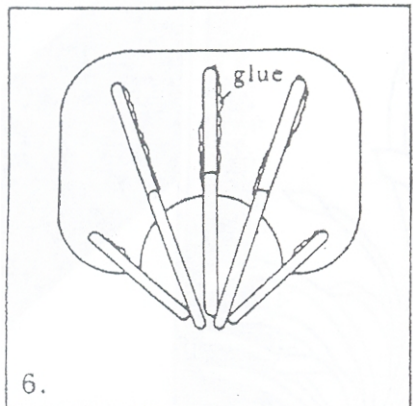

6. Turn the fan-front face down. Glue the 3 ribs as shown. Then glue a single small Popsicle stick to each corner as shown.

7. Put glue all of the back of the fan-front and the sticks. Carefully place fan-back over fan-front, matching up the edges. Press firmly.

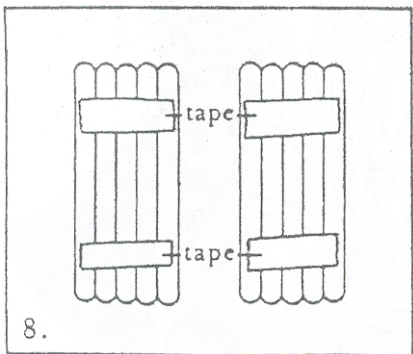

8. Place 3 large Popsicle sticks on a flat surface, side by side. Put a strip of masking tape along the top and bottom. Do the same with 3 more sticks. Each group of sticks will be half the handle of the fan.

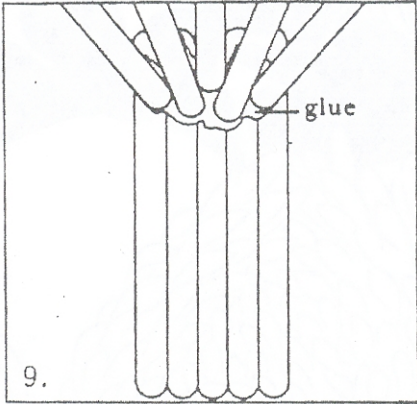

9. Turn one half of the fan handle over so the masking tape is on the bottom. Spread glue on the top inch or so. Then press the ends of the fan ribs into the glue as shown.

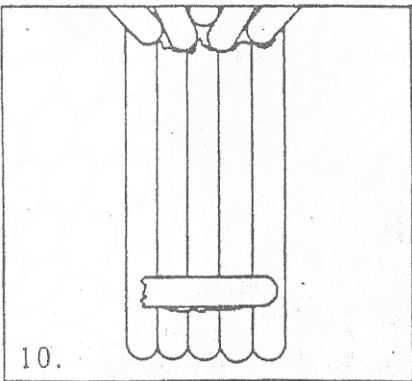

10. Break a small piece (less than 2 inches) off the last small Popsicle stick and glue across handle as shown. Press down and let dry.

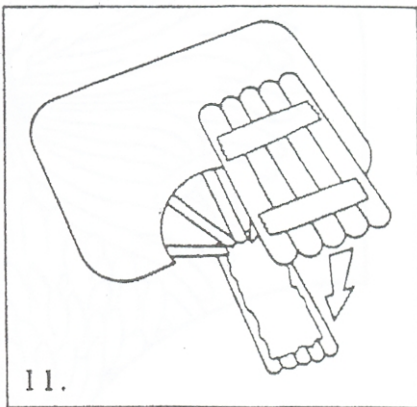

11. Put glue all over the handle half to which you've just attached the stick piece. Making sure masking tape is on top, press down other half of handle onto the half with the glue as shown. Let dry.

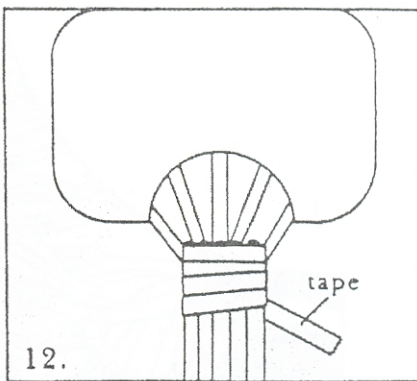

12. Wrap the masking tape around the handle from the top to the bottom.

13. Decorate and embellish fan and handle to finish.

Illustrations



A student works to build the ribs and handle of fan. Note small sticks used on ribs, with three larger sticks creating one half of the handle.



One possible method of embellishing is to use metallic markers.



The floral fan pattern can be decorated with colored pencils, markers, crayons, etc.



Two finished samples.